



**WVS-TECHNOLOGY**

# WVS-TECHNOLOGY

**WALTER V. STEINFELD, DIPL.-ING.**

**ROBERT-BOSCH-STR. 7 TEL.: +49 (0) 2150 - 91 28 10  
D - 40668 MEERBUSCH FAX: +49 (0) 2150 - 91 28 11**

## HF WELDING MACHINE

## AUTO INDEXER

High Frequency welding with Auto Indexer are used to produce technical articles or packaging for a mass production: blister packaging, technical articles.  
We can install only the Auto Indexer on an existing Press with all Accessories or Options.

### PROGRAM OF WELDING MACHINE WITH AUTO INDEXER:

- Delay time of filament heating
- Detection of excess current
- Supervision of antflash
- Continuous cycles On / Off

### Cycle of welding and machine:

- Descent & Punching & Uncoiling
- Detection of low position press
- High Pressure control
- Delay time of Welding
  - Two powers starting
- / Film pinching
- / Pulling
- Delay time of cooling
- Pneumatic cylinder rise
- Film pinching
- Film pulling
- Counting down of number of solders



### Displays as you prefer:

- Intensity of welding
- Delay time of welding
- Delay time of cooling
- Time of cycle
- Counting of cycles

Emergency stops - Safety casings - Doors...  
Manual functions for maintenance

References	Electrical Power	Welding Length	Press Stroke	Clearance of Throat	Table Sizes W * D	Triage Indexing Length	Dimensions Machine Sizes								Mass
							A * B * C * D * E * F * G * H								
	VA	W=3.3 mm	mm		mm	mm	mm								kg
<b>PSM-L 6000 AI</b>	6000	2200	80	275	700 * 430	600	740 * 1115 * 1000 * 680 * 700 * 1525 * 1655 * 3035								600
<b>PSM-L 10000 AI</b>	10000	3500	100	325	800 * 550	750	880 * 1215 * 1000 * 880 * 800 * 1600 * 1850 * 3235								800
<b>PSM-L 16000 AI</b>	16000	5000	150	420	800 * 660	750	950 * 1300 * 1000 * 900 * 800 * 1750 * 2000 * 3400								1100

### Specifications:

Electric Supply : 400V 3-phase + ground - 50 / 60 Hz  
Compressed air = 10 litres/min ou 20 litres/min  
Pneumatic Cylinder diameter = 100 - 120 - 160 mm  
Drawing upon safety standard : Carters ; Norms CE.  
Antiflash with Grid Blocking  
Roll Numbers = 5 Maxi

### Options:

Heating plate of tools : up to 150°C  
Pneumatic Clamping of Plate Tools for quickly change product  
Automatic Knife on Output to facilitate stocking  
Robot for stack of bags  
Indexing on printed Pattern  
Ultra Fast Antiflash  
Printer between HF Press and Indexer = **Inkjet Printer on line!**

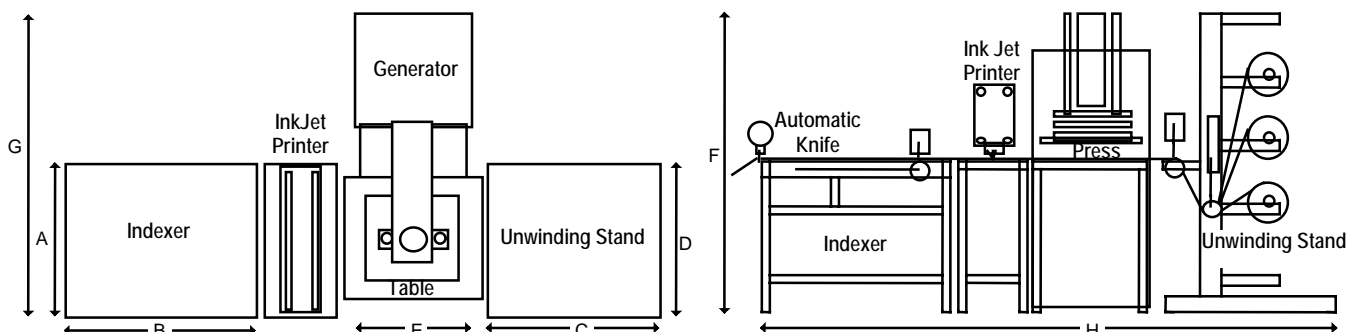

Homepage: [www.wvs-tech.de](http://www.wvs-tech.de)

E-mail: [info@wvs-tech.de](mailto:info@wvs-tech.de)

*Precision makes the Difference in Performance*